

GEM DPSS CONTINUOUS WAVE LASER SERIES

COMPACT AND RELIABLE WITH HIGH SPECIFICATIONS

Novanta develops photonics solutions specializing in cutting-edge components and sub-systems for laser-based diagnostic, analytical, micromachining and fine material processing applications. Powerful lasers, coupled with advanced beam steering and intelligent sub-systems incorporating software and controls, deliver extreme precision and performance, tailored to our customers' demanding applications.

BUILT FOR OEMS

The gem range is the OEM laser of choice. Designed for easy integration into OEM instrumentation the gem series incorporates high output power from a compact platform, exceptional wall plug efficiency for effective thermal management and robust optomechanical design to support high reliability, 24/7 system integrated applications. Advanced design features including an integrated power feedback for exceptional power and spectral stability and fiber coupling solutions will benefit a range of applications from Super Resolution Microscopy, Raman Spectroscopy and Hologram Replication through to Semiconductor inspection and Particle Counting.

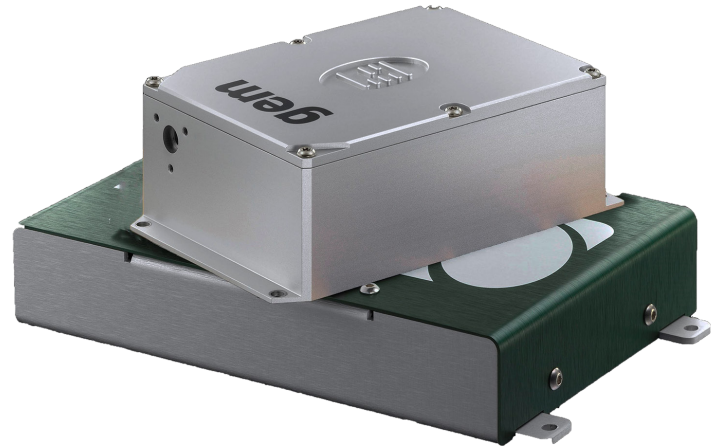
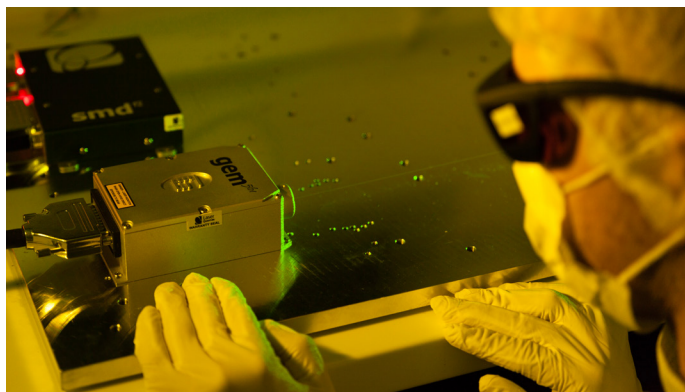

The gem laser available in a range of wavelengths and powers

UNIQUE FEATURES

OEM focused platform

- Flexible, customizable platform to meet exact OEM integrator requirements.
- Advanced features including high power SM and MM fiber coupling solutions and high power/footprint ratio.
- Robust optomechanical design for prolonged longevity and minimized downtime

Exceptional performance supporting consistent and repeatable results.

- Exceptional power stability and low noise for high repeatability, resolution and consistency in a diverse array of application
- High power on sample via either free space or fiber delivery.

Ease of integration

- High wall-plug efficiency for effective thermal management – Air cooled solutions.
- Simple plug and play solution increasing productivity and allowing for field replacements.
- Compact laser head and psu; easy to design in new or retrofit in existing OEM instruments.

GEM DPSS CONTINUOUS WAVE LASER SERIES

PERFORMANCE DATA

The gem range is a series of compact lasers designed for easy OEM integration. With a wide power range and multiple wavelength offerings, the gem is ideal for system designers requiring a reliable, robust laser with excellent beam quality. All gem lasers are high specification single transverse mode CW lasers, ideal for many applications such as Raman and super-resolution microscopy. The gem range has a long industrial heritage, delivering extended performance lifetimes that truly enable it to be treated as a black box - to be installed and forgotten (Fig. 1).

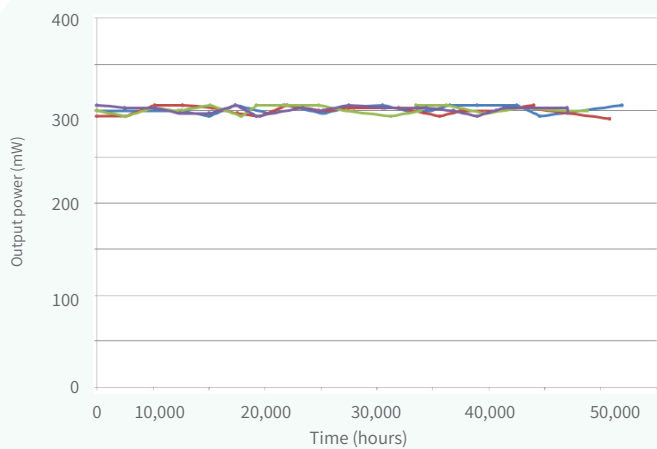

Fig. 1 Output power from 4 gem lasers, showing stable output over 45,000 hours, with minimal increase in required diode current.

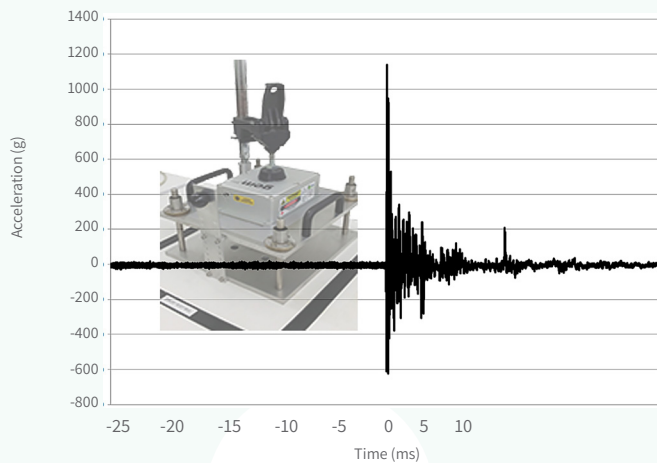

Fig. 2 Accelerometer trace showing the 1200 g shock experienced by all Laser Quantum lasers prior to testing.

FLEXIBLE DESIGN

Customizable options available for your laser to optimize your application.

- **Fiber coupling:** Available with multi or single mode fiber delivery options which allows the beam to be delivered to the point of need.
- **Intelligent control unit:** Allows easy setting and monitoring of the laser parameters. Incorporating PowerLoQ™ technology, the gem lasers show extreme power stability over long periods of use.
- **1200 g drop-test:** (Fig. 2) All gem lasers undergo a drop test to check that all components are correctly fitted prior to its extended 300 hour test period. This rigorous testing regime ensures long operational lifetimes.
- **RemoteApp™:** Works with software that allows the laser to be controlled locally, over the internet and connected directly to our support team for monitoring laser performance, diagnosing opportunities and carrying out laser optimization.
- **Available in a range of wavelengths and powers:** The gem family of lasers are designed for integration into instruments as a fit-and-forget laser source, with exceptionally long operation lifetimes.

GEM DPSS CONTINUOUS WAVE LASER SERIES SPECIFICATIONS

Specification	gem 532	gem 561	gem 640	gem 660	gem 671
Wavelength	532 nm	561 nm	640 nm	660 nm	671 nm
Power	100 - 2000 mW	100 - 1000 mW	100 - 500 mW	100 - 1000 mW	100 - 750 mW
Beam Diameter ¹	0.9 ± 0.1 mm	1.0 ± 0.2 mm	1.1 ± 0.2 mm	0.75 ± 0.15 mm	0.75 ± 0.15 mm
Spatial Mode	TEM ₀₀				
Ellipticity	< 1:1.2				
Bandwidth	30 GHz	40 GHz	40 GHz	30 GHz	30 GHz
Divergence	< 0.8 mrad	< 1 mrad	< 1.2 mrad	< 1.5 mrad	< 1.5 mrad
M ²	< 1.1	< 1.2	< 1.2	< 1.2	< 1.2
Power Stability (RMS) ²	< 0.8%	< 1.0%	< 0.8%	< 1.0%	< 1.0%
Noise (RMS)	< 0.8%	< 1.5%	< 0.8%	< 0.6%	< 0.6%
Noise Bandwidth	10 Hz - 6 MHz	10 Hz - 10 kHz	10 Hz - 10 kHz	10 Hz - 10 kHz	10 Hz - 10 kHz
Beam Pointing Stability ³	< 10 µrad/ °C				
Polarization Ratio	> 100:1				
Polarization Direction ⁴	Horizontal				
Coherence Length	~1 cm	~7.5 mm	~7.5 mm	~1 cm	~1 cm
Beam Angle ⁵	< 1 mrad				
Operating Temperature	15 - 40° C	15 - 40° C	22 - 37° C	15 - 40° C	15 - 40° C
Standard Power Supply Unit	smd12	smd12	smd24	smd12	smd12

* Laser Quantum operates a continuous improvement programme which can result in specifications being improved without notice.

1 Beam diameter defined as the average of major and minor 1/e² beam size measured at 25 cm from exit port, at specified power.

2 Test duration >100 hrs. at constant temperature.

3 Measured over 36 hrs. at 22 to 28 °C.

4 Vertical polarization is available upon request.

5 Tolerance relative to head orientation.

GEM DPSS CONTINUOUS WAVE LASER SERIES

DIMENSIONS (mm)

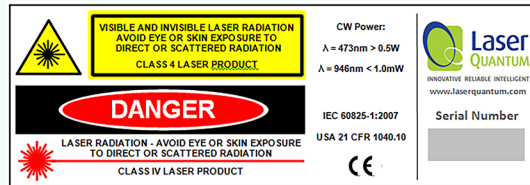
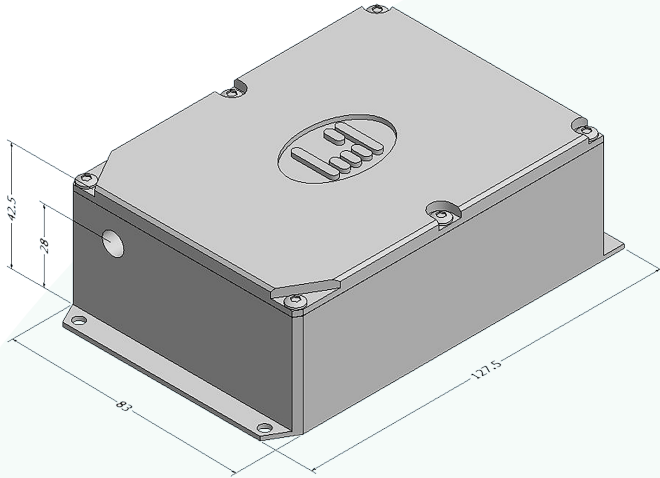

Drawings are for illustrative purposes only, please contact us for complete engineer's drawings

ADDITIONAL INFORMATION

Customizable options available for your laser to optimize your application.

- Weight: 0.75 kg
- Weight: 0.8 kg (gem 640 only)
- Umbilical length: 1.5 m
- Cooling options available
- System can be modulated
- Vertical polarization is available on request
- Fiber coupling available
- LabView drivers available
- 2 years unlimited hours warranty for scientific users

SMD24 POWER SUPPLY UNIT

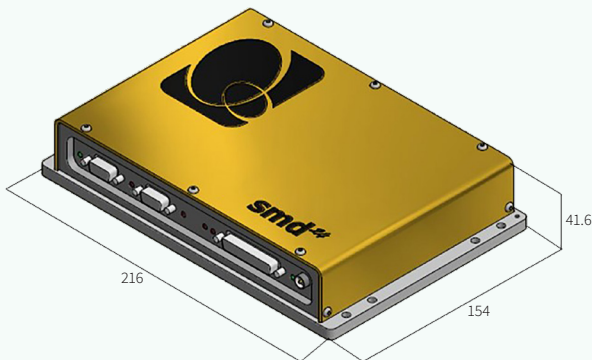

SMD12 POWER SUPPLY UNIT

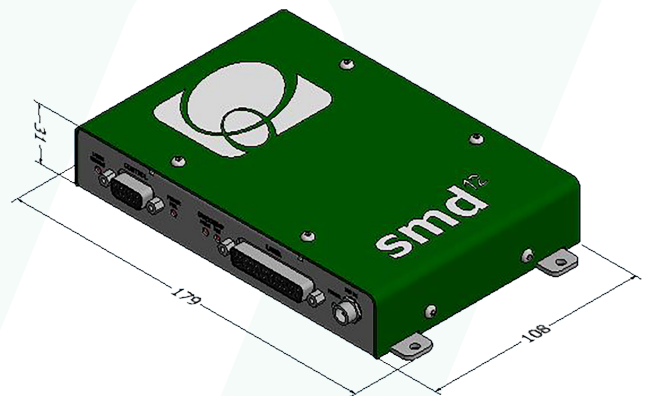

CONTACT US

Americas, Asia Pacific

Novanta Headquarters
Bedford, USA
P +1-781-266-5700

Photonics@Novanta.com

Europe, Middle East, Africa

Novanta Europe GmbH
Wackersdorf, Germany
P +49 9431 7984-0

Milan, Italy
P +39-039-793-710

Photonics@Novanta.com

China

Novanta Sales & Service Office
Shenzhen, China
P +86-755-8280-5395

Suzhou, China
P +86-512-6283-7080

Photonics.China@Novanta.com

Japan

Novanta Service & Sales Office
Tokyo, Japan
P +81-3-5753-2460

Photonics.Japan@Novanta.com