

ATLEX-FBG Series

Compact, high efficient excimer laser
for Fiber Bragg Grating (FBG) writing

Key Features:

- TMC (Total-Metal-Ceramic) Vessel
- Corona Preionization
- Solid State Switch
- Laser Head Volume < 3 l
- Air Cooled / Optional Liquid Cooled
- Flushable Optics Holder
- Integrated 4-Valve System for Easy Gas Handling
- RS485, RS232, USB and FOC Interface for System Integration
- Energy Stabilization Unit
- Integrated Vacuum Pump & Halogen Filter
- Meets European CE Standard, RoHS Compliant



Technical Data

Gas Medium	ArF	KrF	Units
Wavelength	193	248	nm
High Voltage Switching Technique	Solid State Switch		
Maximum Pulse Energy ¹⁾	8	15	mJ
Stabilized Pulse Energy	4	8	mJ
Stabilized Average Power			
ATLEX-300-FBG	1.2	2.4	W
ATLEX-500-FBG	2	4	W
Max. Rep. Rate			
ATLEX-300-FBG	300		Hz
ATLEX-500-FBG	500		Hz
Spatial Coherence ²⁾ (Vertical Beam Direction)	> 300		µm
Pulse Duration ²⁾	5 - 8		ns
Beam Dimensions ²⁾ (V x H)	4 x 6		mm
Beam Divergence ²⁾ (V x H)	1 x 2		mrad
Energy Stability (Stand. Dev.)	< 2		%
Dimensions (L x W x H)	540 x 470 x 370		mm
Weight	60		kg
Cooling	Air / Liquid		
Power Requirements	230 VAC / 6,3 A / 50-60 Hz / 1 Phase		

All specifications are typical data and subject to change without notice due to product improvements.

¹⁾ Measured at 20Hz; allow 10% reduction of output energy and power for laser equipped with stabilization mode

²⁾ Typical Value, FWHM

ATLEX-FBG Series Dimensions



Rear view

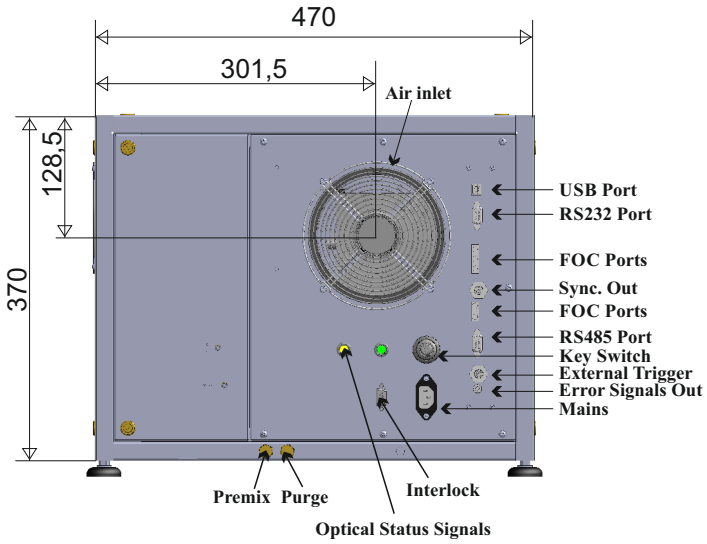

Side view

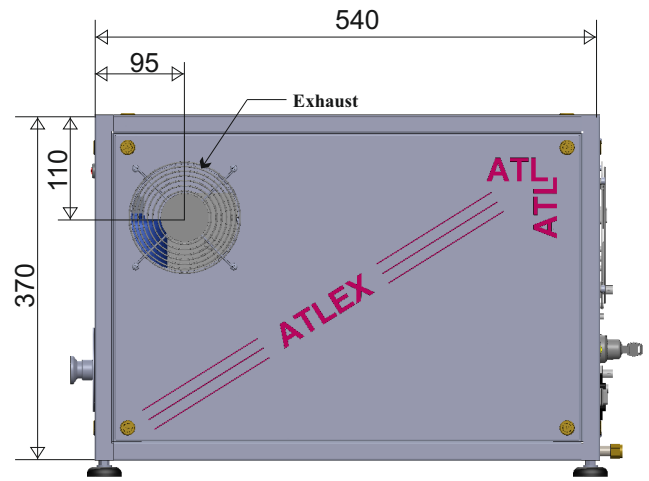

Front view

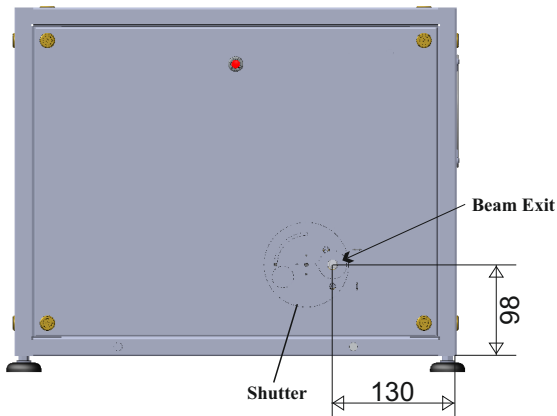

Bottom view

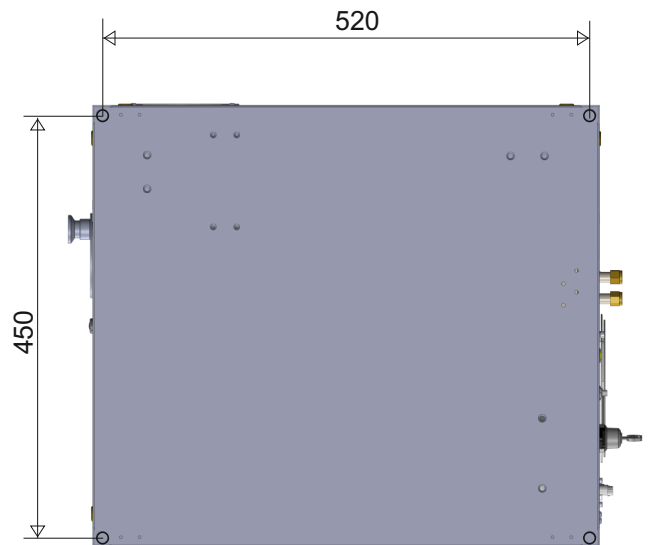

All dimensions in mm

ATLEX-FBG complies with the Federal Regulations (21 CFR Subchapter J) as administered by the Center for Devices and Radiological Health.

ATL Lasertechnik GmbH
Burger Str. 28
D-42929 Wermelskirchen
Tel.: +49 (2196) 88 79 893
Fax: +49 (2196) 88 79 895
Internet: www.atl-laser.de



Visible and invisible Laser Radiation. Avoid eye or skin exposure to direct or scattered Radiation. CLASS IV Laser radiation product per EN60825-1 (1994).